

BUILD A COMPOST BIN

CONSTRUCTION PLAN



Difficulty level: **TTT** | Intermediate

Completion time: **Project Week-end**

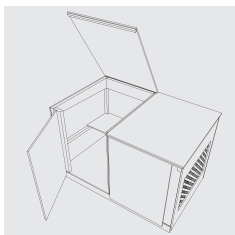
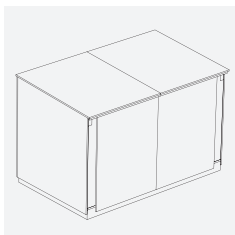

BUILD A COMPOST BIN

Not only is composting an environmentally responsible way of ridding of perishable waste, but it also makes for an excellent (and free!) fertilizer to enhance your landscape or garden. Construct your own compost bin to start composting. The Intermediate DIY-er could complete your bin in a weekend, while the more experienced could complete it quicker.

The plan propose a treated wood bin that measures 38" height x 61" wide x 31" deep which is a fairly good size. With the proper bin, instructions and a little dedication, you'll be composting your home's waste in no time. Implement a compost bin into your home's procedure for both environmental waste reduction and top-quality fertilizer.



TOOLS AND MATERIALS NEEDED

TOOLS

- > 3/8" bit
- > 1/2" bit
- > 3" hole saw
- > Bevel square (optional)
- > Circular saw
- > Compass (optional)
- > Drill
- > Jigsaw
- > Mitre saw (optional)
- > Sandpaper
- > Screwdriver
- > Square
- > Tape measure

MATERIALS

- > 4 lengths spruce 2" x 2" x 96"
- > 1 length treated lumber 2" x 4" x 120"
- > 1 length treated lumber 2" x 4" x 144"
- > 1 length treated lumber 2" x 6" x 120"
- > 1 length treated lumber 2" x 6" x 144"
- > 1 sheet treated wood lattice 1/2" x 4" x 96"
- > 4 galvanized steel handles
- > 4 sheets treated plywood 1/2" x 4" x 96"
- > 8 galvanized steel hinges
- > 1 box 100 - 1 1/2" treated wood screws
- > 1 box 100 - 2 1/2" treated wood screws
- > 1 box 50 - 1" treated wood screws
- > 1 box 50 - 1/2" treated wood screws
- > 1 galvanized steel latch (optional)

NOTE ON TREATED WOOD

TREATED WOOD SHOULD BE HANDLED WITH PRECAUTIONS.

- Wear gloves and long sleeves when handling treated wood to avoid skin contact and to protect against splinters.
- Wear dust mask, eye protection, gloves and long sleeves when sawing, sanding or shaping treated wood to avoid skin contact with or inhalation of sawdust, to protect against splinters and to protect eyes from flying particles. When making cross cuts, use a cut sealer as the factory-treatment rarely goes to the heartwood.

DURING CONSTRUCTION

- Apply a wood preservative on the cut ends.
- Use nails, screws, bolts, connectors and other hardware resistant to corrosion: stainless steel, hot dipped galvanized, yellow zinc or other hardware specially coated for outdoor use. Ordinary fasteners will rust, causing unsightly stains and weakening the structure, ultimately causing it to fail.

BUILD A COMPOST BIN

- Make certain the wood is thoroughly dry before painting or staining, and follow the coating manufacturer's recommendations. Use only good quality oil or acrylic coatings on water repellent pressure treated wood.
- Do not dispose of treated wood remnants or sawdust in compost heaps, wood chips, or mulch.
- Do not use it as animal bedding or litter.

Never burn treated wood.

ELEVATIONS

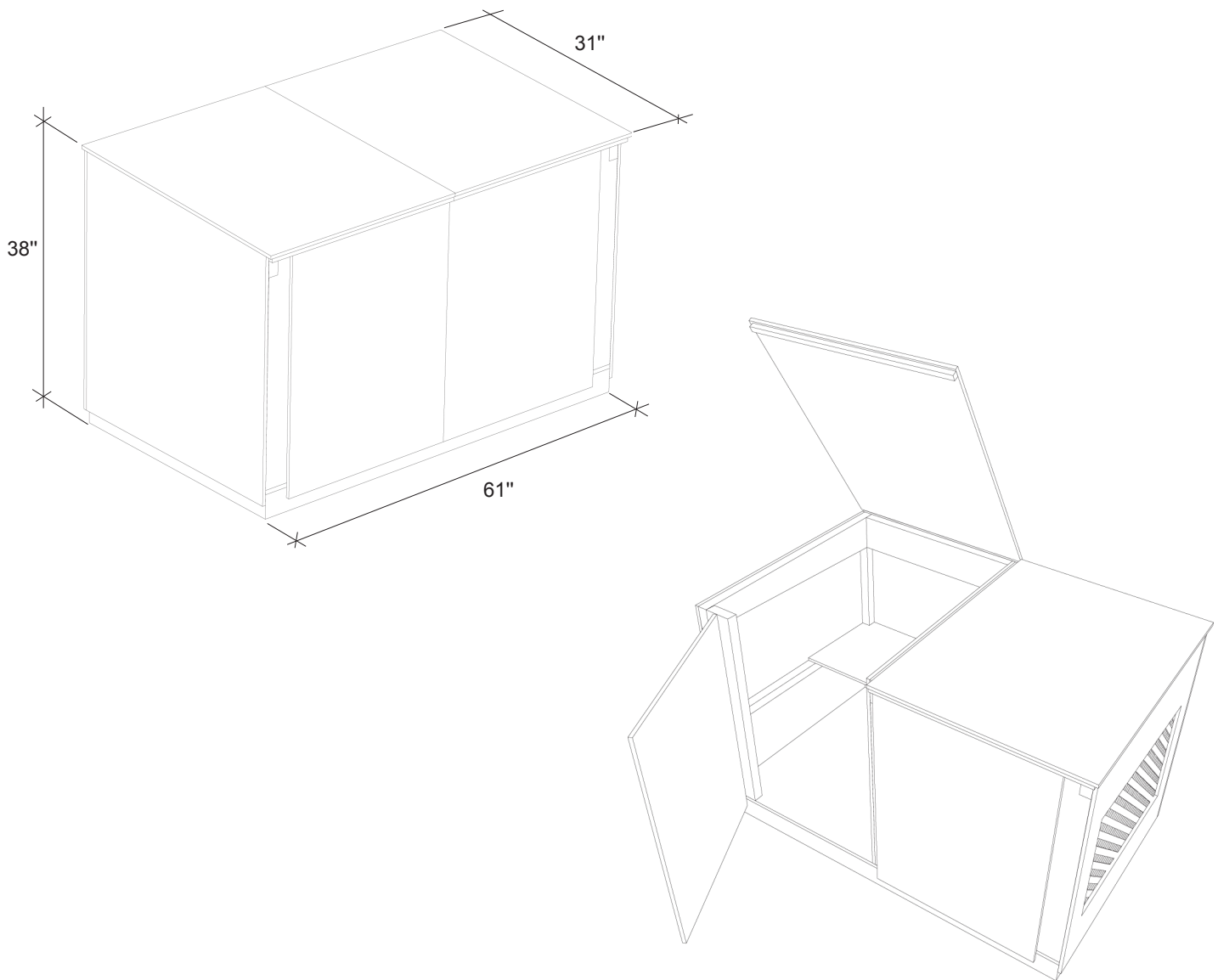

BUILD A COMPOST BIN

PREPARATION

Cut and prepare all the pieces of wood. Make sure you number each part clearly, as shown on the images.

FLOOR STRUCTURE

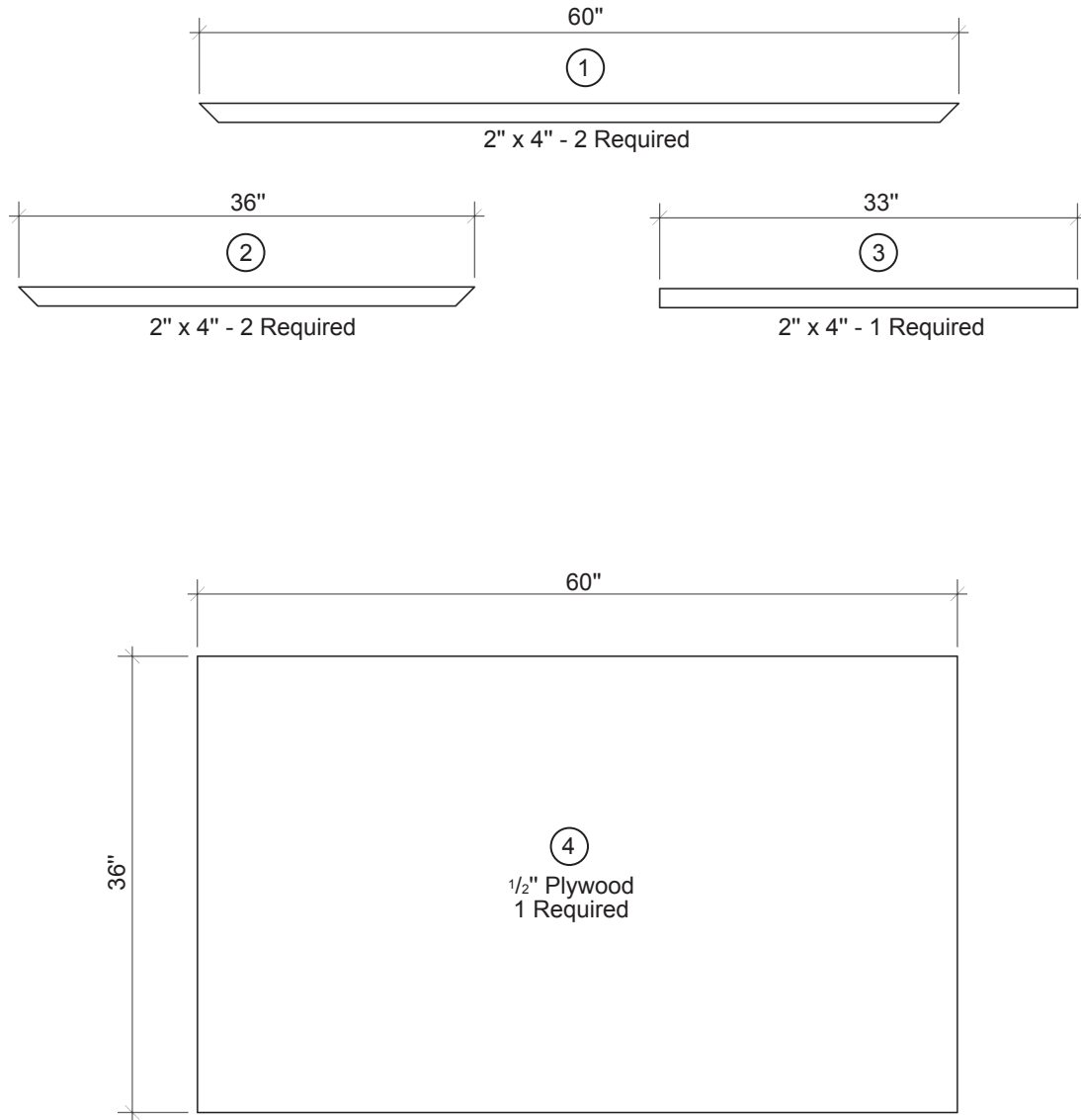

BUILD A COMPOST BIN

SIDES FRAMES

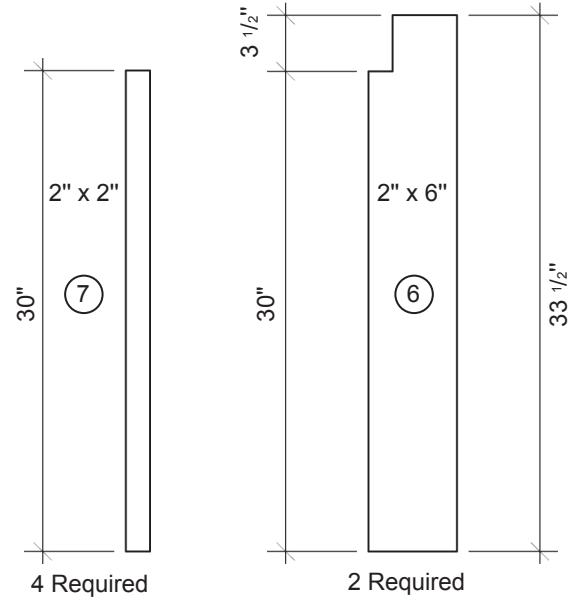
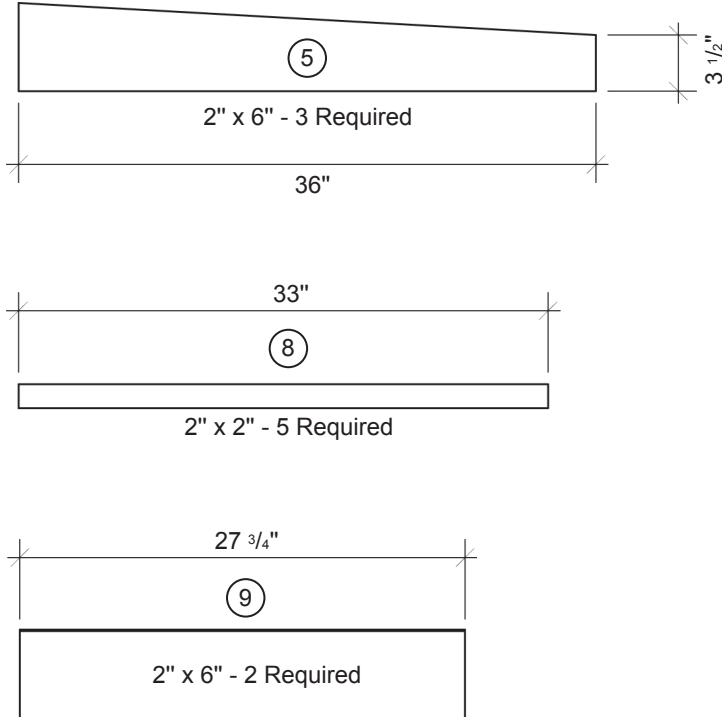

SHELVE

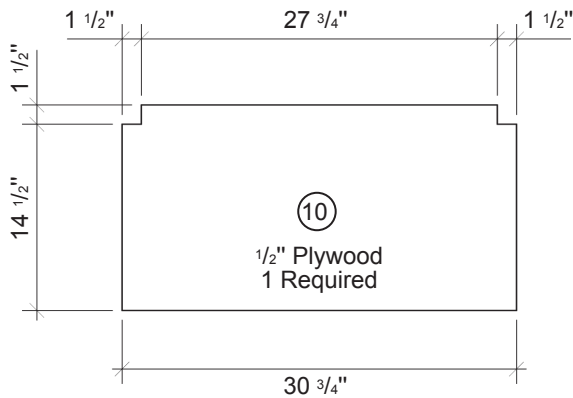

BUILD A COMPOST BIN

SIDE PANELS

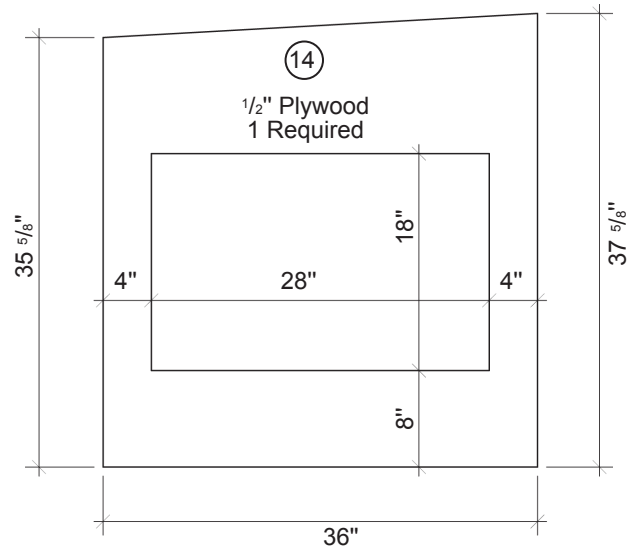
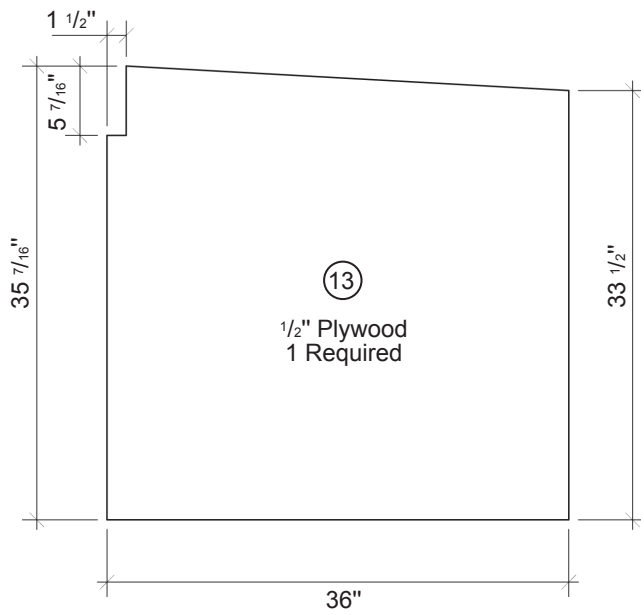
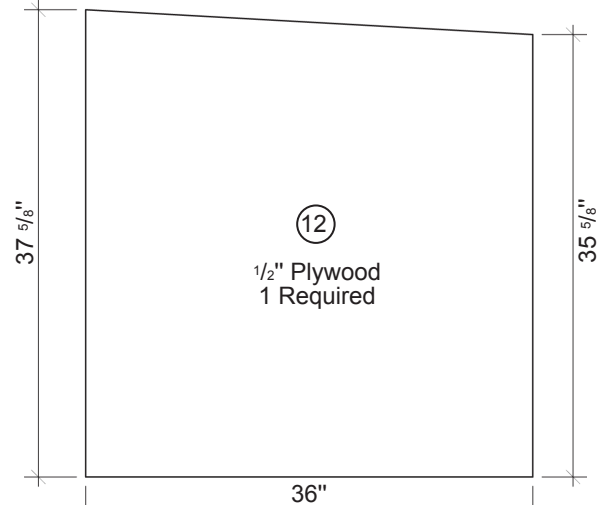
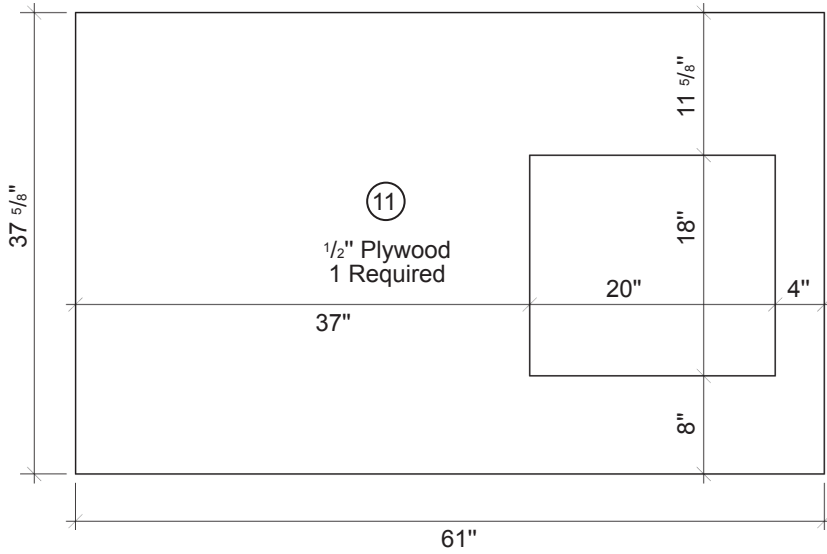

BUILD A COMPOST BIN

LATTICE FRAMEWORK

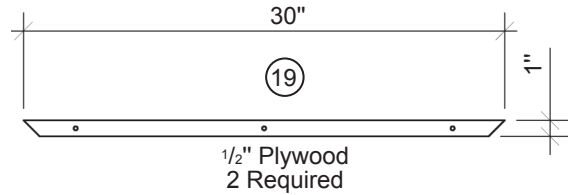
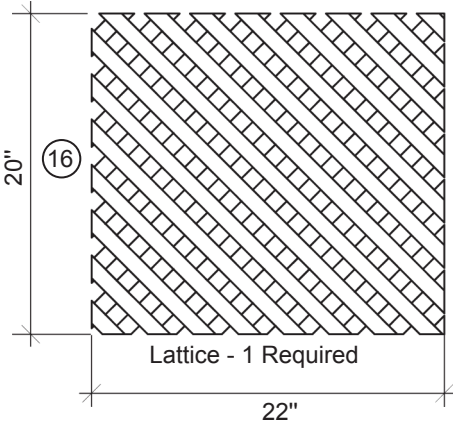
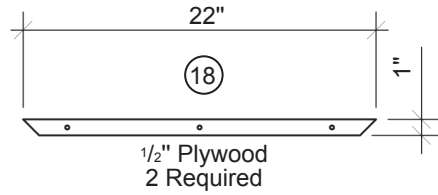
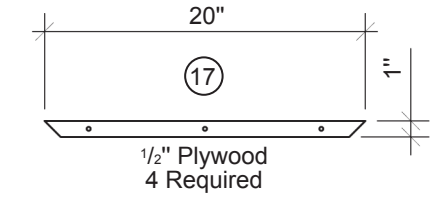
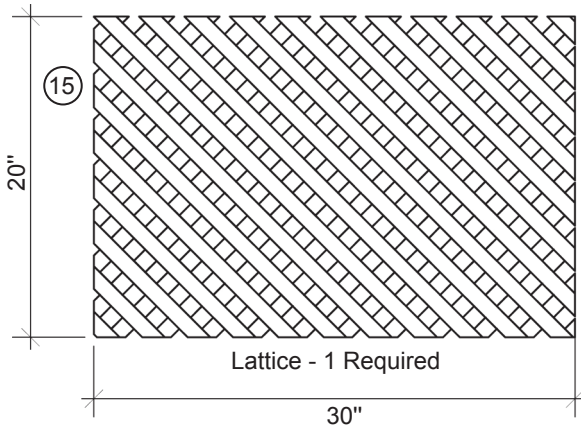

COVER

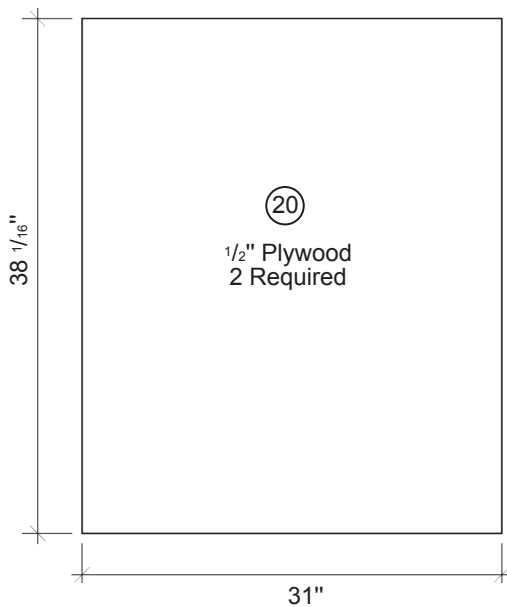
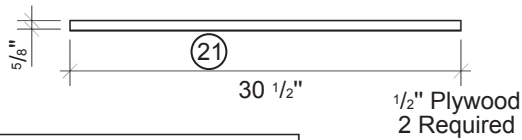

DOORS

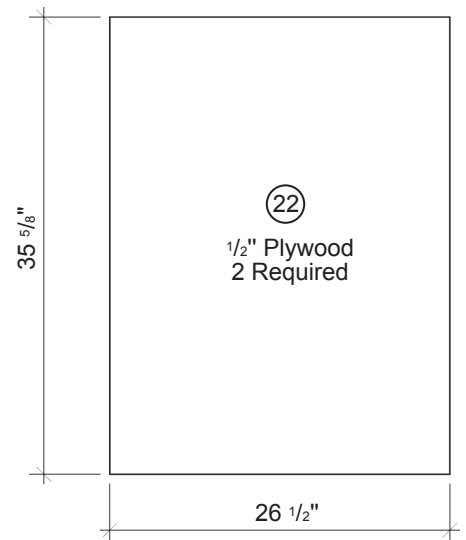

BUILD A COMPOST BIN

ASSEMBLY

1 ASSEMBLE THE BASE OF THE BOX

1.1 Pre-drill the holes and assemble parts 1, 2 and 3 using 2 ½" treated wood screws.

1.2 Install plywood panel 4, which forms the bottom of the box using 2 ½" screws.

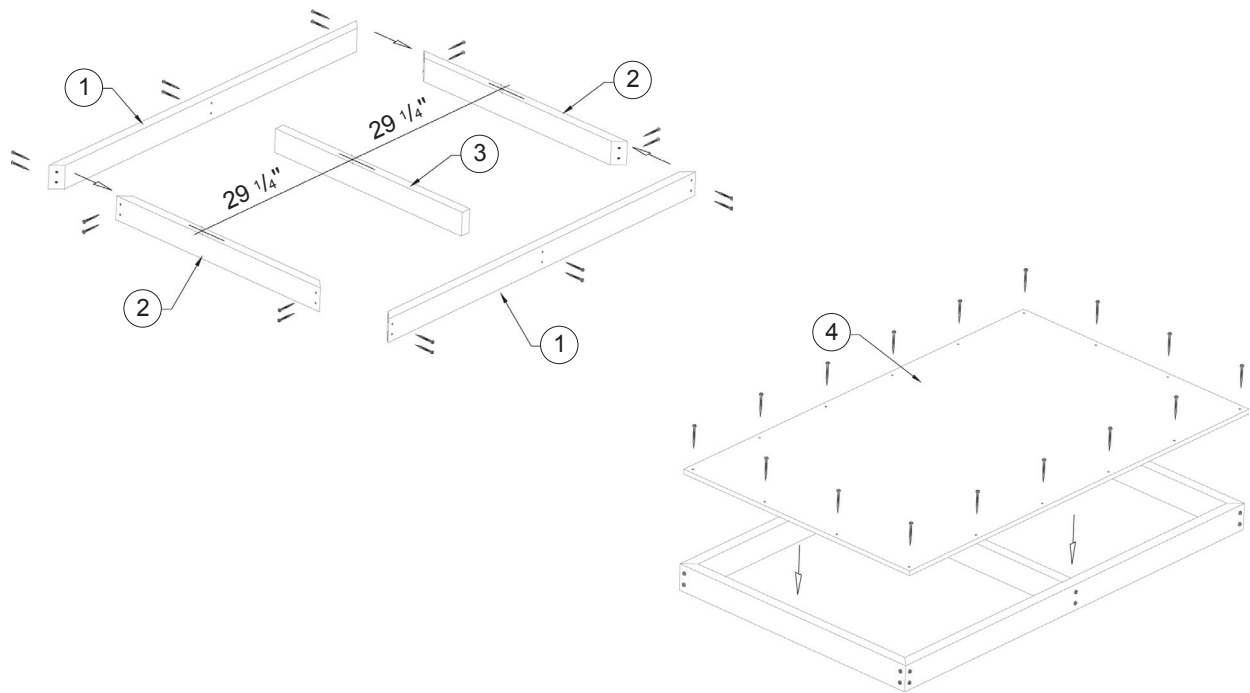

2 BUILD THE SIDE FRAMES

2.1 Pre-drill holes in part 8 that will be used to attach to the base.

2.2 Assemble the side frames parts 5, 6, 7 and 8.

2.3 Insert 2 ½" screws into the predrilled holes in part 8 and fix the side frames into place in the base of the box.

BUILD A COMPOST BIN

ASSEMBLY

2 2.4 Using 2 1/2" screws, assemble part 9, which make up the back frame of the box.

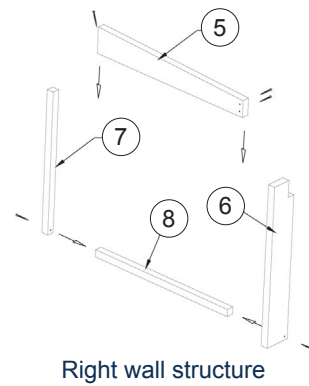
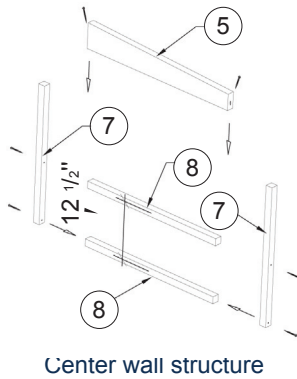
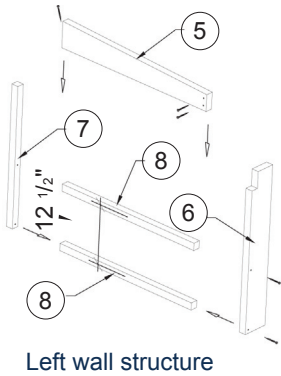

2.5 Pre-drill holes in shelve 10 and secure it in place with 1 1/2" screws.

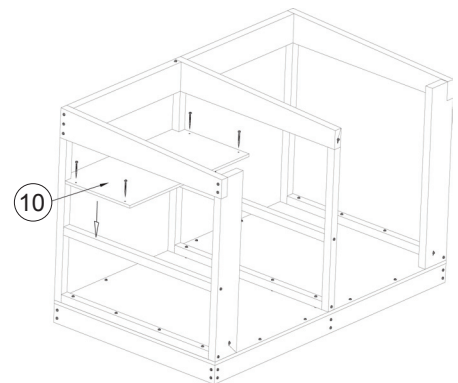
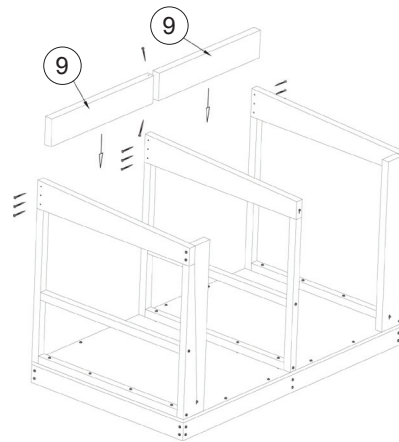
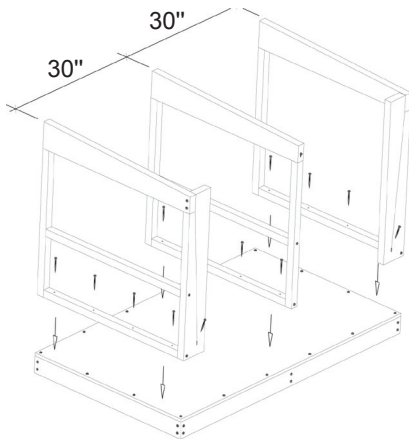

BUILD A COMPOST BIN

ASSEMBLY

3 PLACE THE SIDE PANELS

- 3.1 Install all the plywood sides using 2 ½" screws.
- 3.2 Attach the lattice framework on the inside of the box.

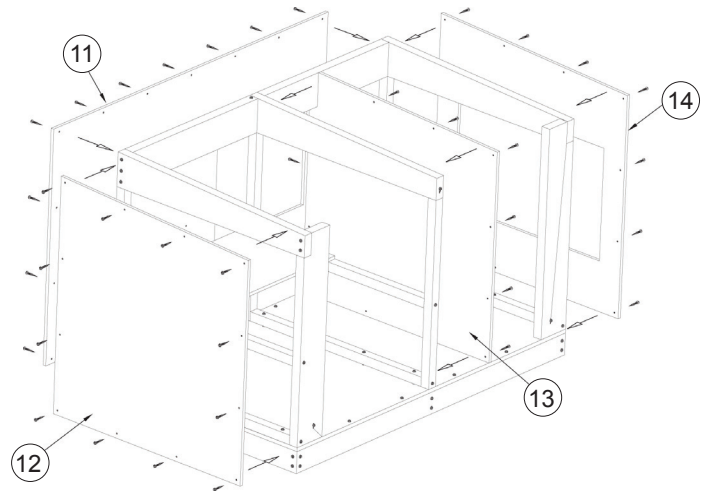

- 3.3 Secure the lattice using 1" screws, and its frames over the openings.

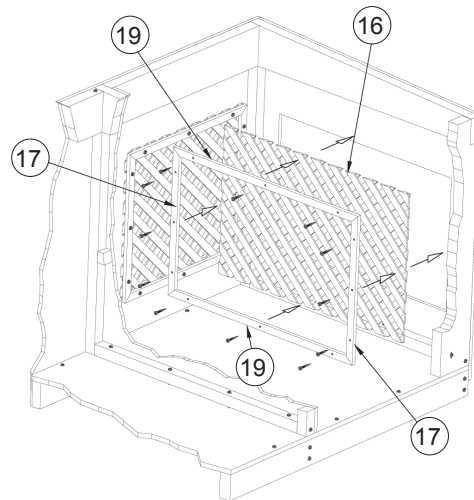
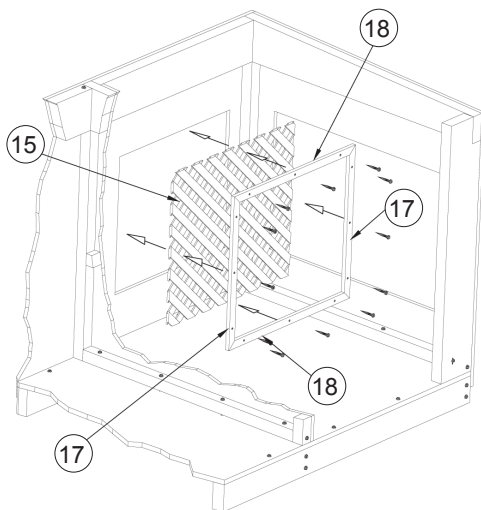

4 INSTALL THE COVER AND FRONT DOORS

- 4.1 Make sure the cover door hinges are placed on the back edge of the box so that the door opens fully.
- 4.2 Place the doors so that they meet in the centre of the box and calculate the distance required for the hinges.
- 4.3 Secure the top door hinges with 1" screws

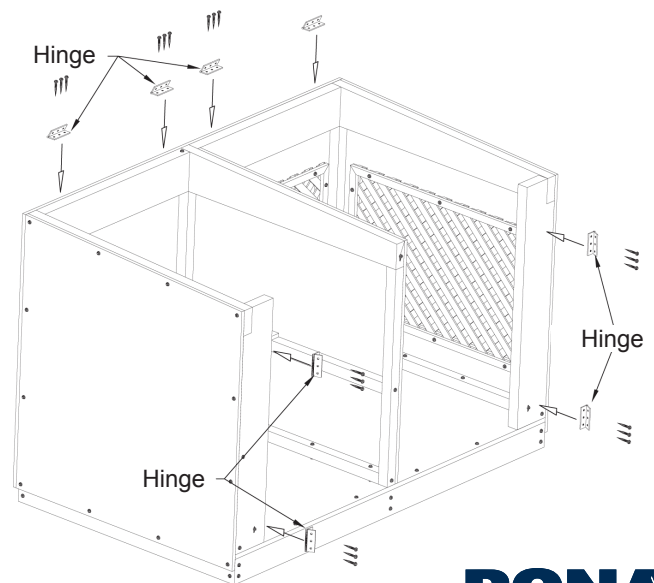

BUILD A COMPOST BIN

ASSEMBLY

4 4.4 Secure the hinges for the front doors using ½" screws.

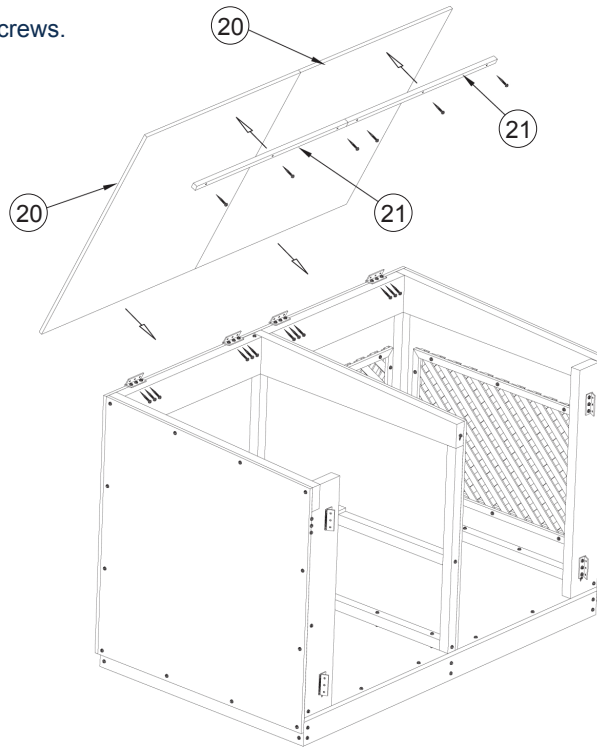

4.5 Attach part 21 to the edges of the top cover doors.

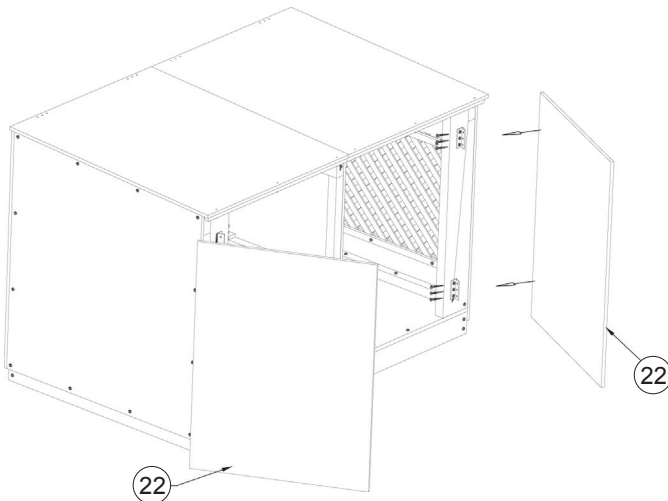

4.6 Attach the doors to the hinges using ½" screws.